

Creston

Model # 5881

Creston Patio Planter



DESCRIPTION

The Creston planter offers a fresh modern looking design. The angled top shape creates a unique and elegant look providing a beautiful accent to the entrance of any home.

- 100% polyethylene planter with UV inhibitors
- Weather resistant, low maintenance material
- Double wall molded design
- Warranty: 15-Yr Residential Use / 5-Yr Commercial Use

PRODUCT DIMENSIONS

Outside Dimensions: 15.6in DIA x 28in H (39.6cm x 71.1cm)

Inside Dimensions: 12.6in DIA x 11.3in D (32cm x 28.6cm)

Soil Capacity: 4.1 Gallons (15.5 Liters)

Wall Thickness: 0.12in (3mm)

Part Weight: 6.5lbs (3.0kg)

Material: Polyethylene

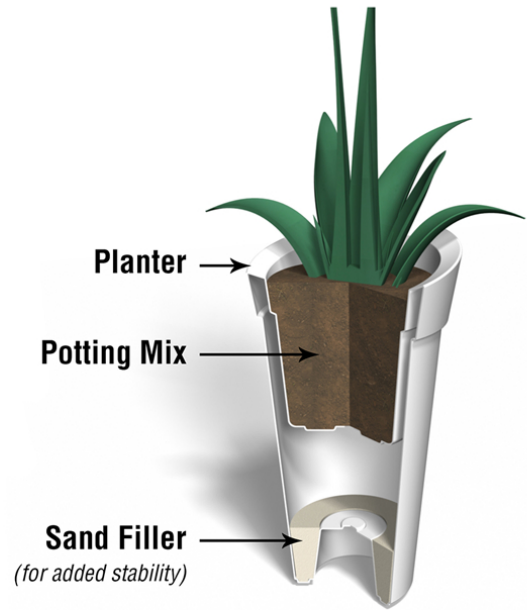
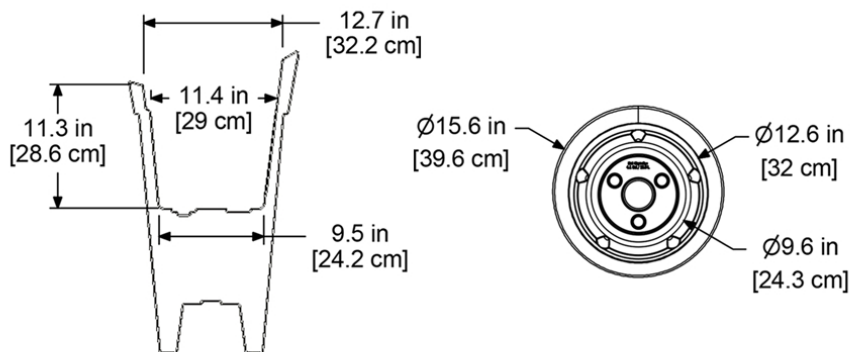
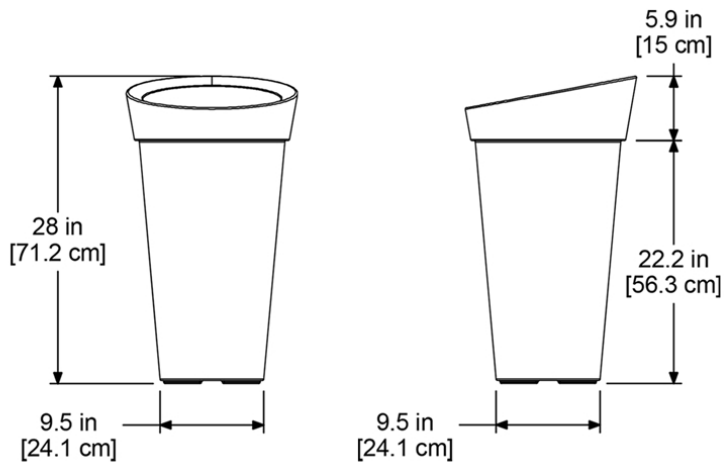

MAYNE[®]
Outdoor Products of Distinction

7024 Kilbourne Rd - Unit A London, ON N6P 1K6

Tel: 866-363-8834 | www.gomayne.com

customerservice@gomayne.com